

02_Management

MAN_ControlLine [FB2]

MAN_ControlLine Properties

General							
Name	MAN_ControlLine	Number	2	Type	FB	Language	LAD
Numbering	Automatic						
Information							
Title	Control Line - Sequential algorithm	Author		Comment		Family	
Version	0.1	User-defined ID					

Name	Data type	Default value	Retain
▼ Input			
ButtonStart	Bool	false	Non-retain
ButtonStop	Bool	false	Non-retain
ModeManual	Bool	false	Non-retain
ModeAuto	Bool	false	Non-retain
GlobalError	Bool	false	Non-retain
FirstScan	Bool	false	Non-retain
▼ Output			
StartLine	Bool	false	Non-retain
StopLine	Bool	false	Non-retain
AlarmSiren	Bool	false	Non-retain
InOut			
▼ Static			
s1	Bool	false	Non-retain
s2	Bool	false	Non-retain
s3	Bool	false	Non-retain
s4	Bool	false	Non-retain
P_ButtonStart_1	Bool	false	Non-retain
P_ButtonStart_2	Bool	false	Non-retain
IEC_Timer_0_Instance	TP_TIME		Non-retain
Run	Bool	false	Non-retain
N_Run	Bool	false	Non-retain
Temp			
Constant			

Network 1: Step 2-1

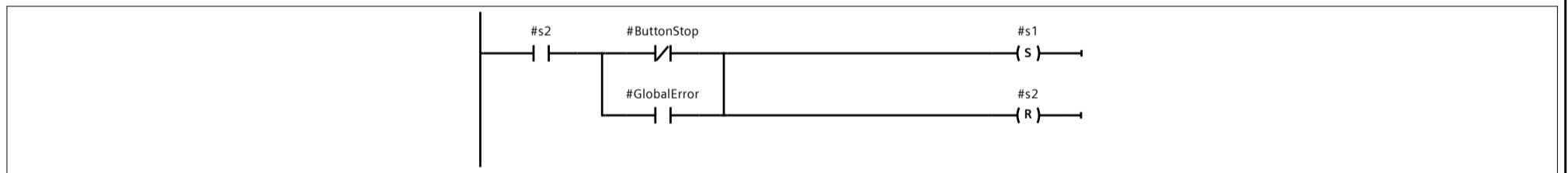

Network 2: Step 4-1

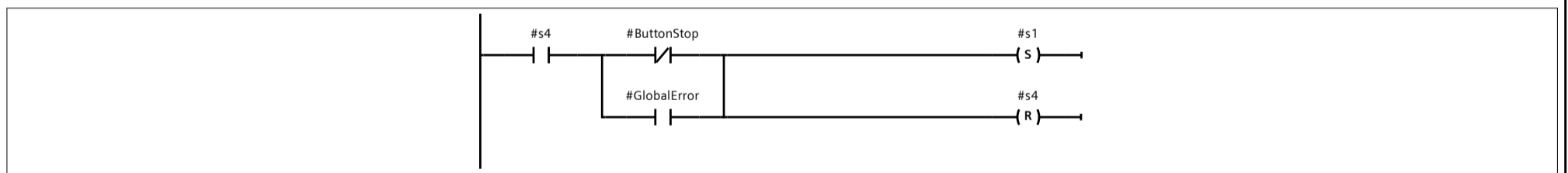

Network 3: Step 1-2

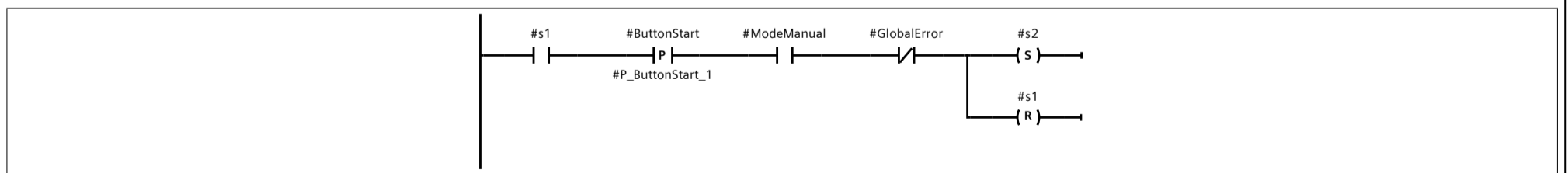

Network 4: Step 3-4

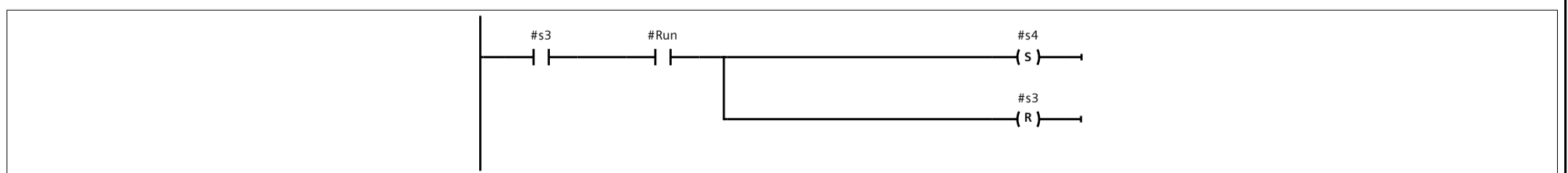

Network 5: Step 3-1

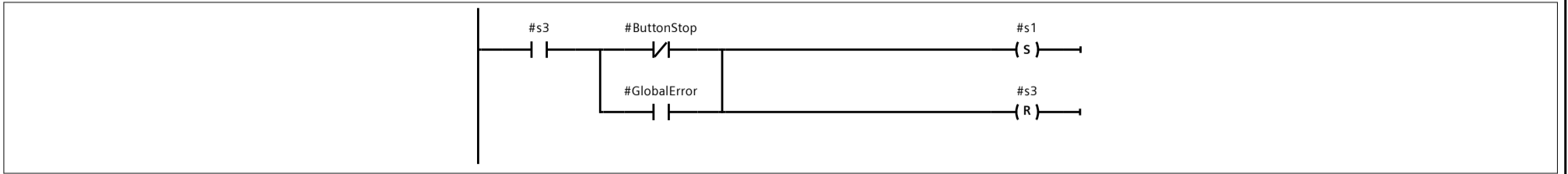

Network 6: Step 1-3

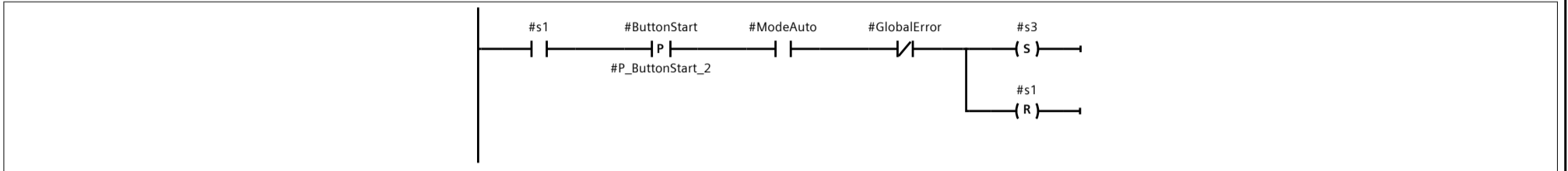

Network 7: Step 1 Output

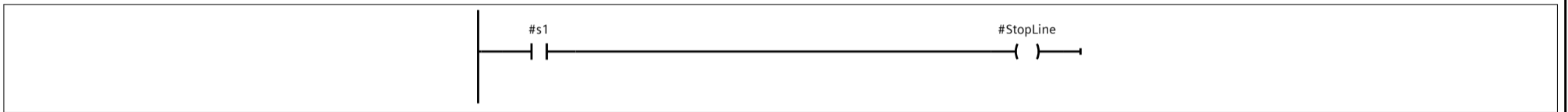

Network 8: Step 2 and 4 Output

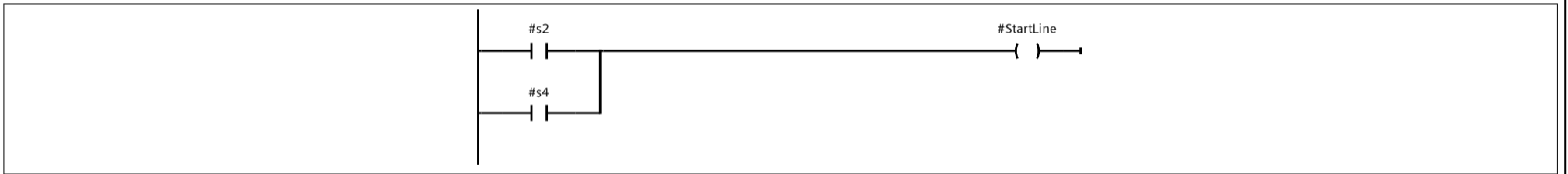

Network 9: Step 3 Output

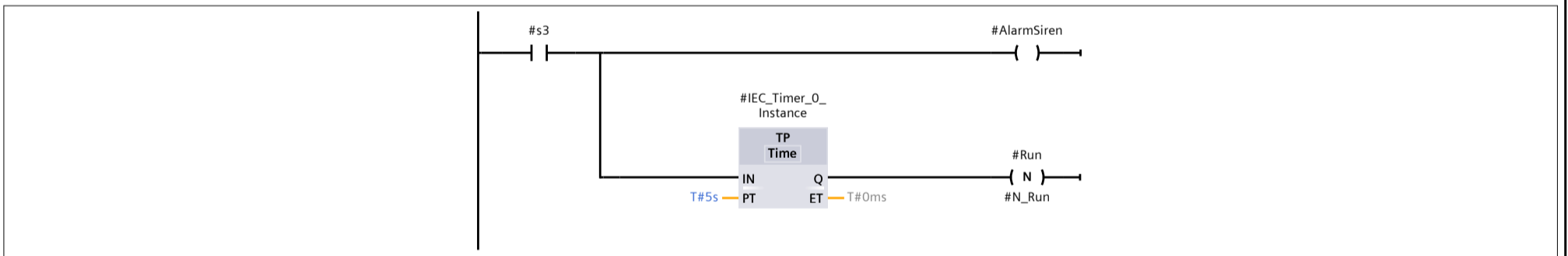

Network 10: First Scan

